

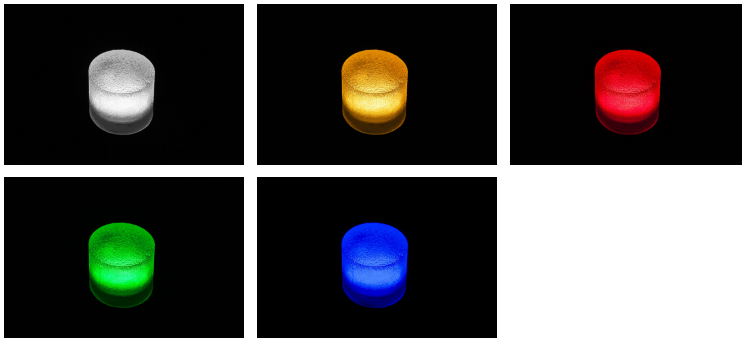

ECO-STONE 80

EXTRA-LOW VOLTAGE - Embedded ELV paving stones





Very low voltage decorative stud

Very low-consumption architectural beaoning solution. Ideal for use as decorative elements in a wide range of contexts, whether public (paved squares, pathways, etc.) or private (terraces, gardens, swimming pools, fountains). Waterproof, highly resistant, long lifespan. Borosilicate Glass for a low ecological footprint.

Applications

Parks / Public squares, Eco-districts, Footpaths

Resistance



Standards



LED Colors



Beaoning

360°, Constant, Vertical

Recycling



Certifications



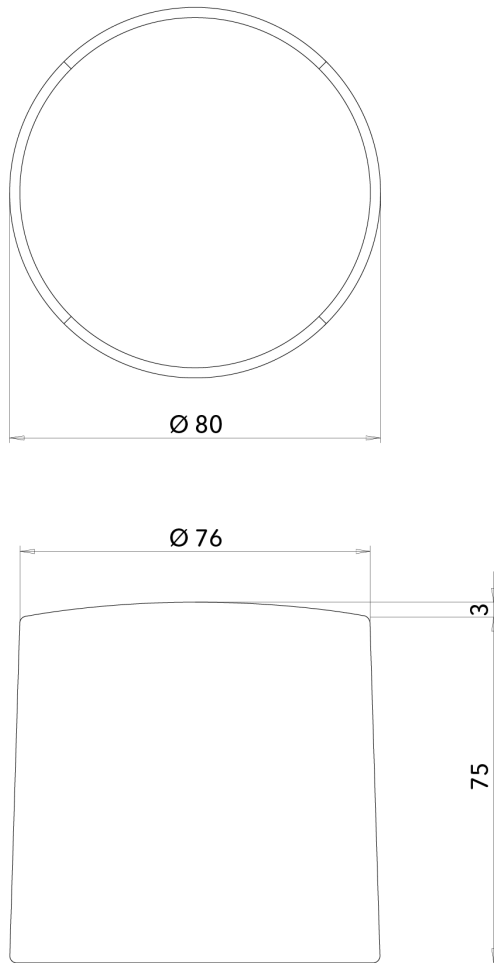

Cables and cable glands not shown. Unit : mm - Tolerance +/- 0.5mm. © Eco-Innov - All rights reserved.

TECHNICAL CHARACTERISTICS

Dimensions

Diameter 80 mm. Height 80 mm (± 2 mm).

Materials

Borosilicate Glass

Recycling managed by ECOSYSTEM.

Power supply / Consumption

12V dc / 0.65 W to 1.4 W depending on LED colour.

Working temperature range

-30°C to +70°C.

Protection index

IP 68 (watertightness).

Pressure resistance

Up to 1 tonne on the surface of the stud.

Accessories

Delivered with 1.5 metres of HO7RN-F 2 x 1 mm² cable.

LIGHTING CHARACTERISTICS

Available colours: white, blue, green, red, amber.

**Laying instructions**

- Choose a suitable transformer (depending on the number of elements connected and the total length of cable).
- Place the luminous paving stones on a bed of sand or gravel or a layer of cement.
- The paving stones must be protected against damage by site equipment (tamping machines, etc.).
- The paving stones must be laid manually.
- The power cable coming out of the paving stone must not be bent or pulled.
- A peripheral joint of at least 5 mm is needed.
- Connect the luminous paving stones to one another and test the installation before final laying.
- The paving stones must be connected and laid by accredited professionals.
- High-pressure cleaning is not recommended.
- Mould treatment may damage the paving stone.

Failure to comply with these instructions may lead to the guarantee being suspended.

Lifespan and warranty

2-year warranty*

Average lifespan more than 10 years (60,000 hours).

* The warranty applies in the event of complete failure of the self-contained lighting system during normal usage. It covers replacement of the faulty article with an identical model delivered free of charge to destinations in metropolitan France, after the faulty article has been returned and analysed. Removal of the faulty article, installation of the new one and any mechanical damage are not covered by the warranty.

Recycling

ECO-INNOV is a founder member of a network that recycles professional WEEE, managed by the eco-organisation ECOSYSTEM. We pay for our customers' electronic safety, lighting and regulation equipment to be collected at the end of its working life in order to meet our legal obligations and help them to meet theirs.

The unique identifier FR006801_05MBCK attesting to registration in the register of producers in the EEE sector, pursuant to article L.541-10-13 of the Environmental Code, has been assigned by ADEME to the company ECO-INNOV (SIRET 451 859 409 00026). This identifier certifies its conformity with regard to its obligation to registration in the register of producers of Electrical and Electronic Equipment and the realisation of its declarations of placing on the market with Ecosystem.

ECO-INNOV is thus one of the first producers to offer its customers a simple and free solution for collecting their professional WEEE, regardless of when it was marketed. The equipment is collected via a network of professional waste collection centres and certain wholesalers.



www.ecosystem.eco